

EUROCARD SERIES 52 AB LINEAR SINE DRIVE SERVO AMPLIFIER

FEATURES

- High performance Linear Servo Amplifier controls brushless linear or rotary motor force or torque
- Linear operating mode does not emit EMI, has high servo stiffness, and no dead zone
- Accepts sinusoidal commutation signals from a digital motion controller
- Sinusoidal control of the motor current minimizes force or torque ripple. This provides very smooth velocity
- Precise nanometer position accuracy can be obtained with sinusoidal control of a linear motor's current
- Operates with low inductance motors
- Current loop bandwidth and the transconductance, amps/volt scale factor, are adjustable
- Fault protection for amplifier over temperature, current overloads, and motor shorts
- Digital inputs for Enable/Reset, Brake, and \pm Travel Limits

APPLICATIONS

- Linear stages, air bearings, and gantry systems
- Integrated circuit manufacturing and inspection
- High accuracy electronic assembly
- High accuracy measurement
- Laser Machining



PRODUCT DESCRIPTION

This size 3U EUROCARD provides closed loop four quadrant force or torque control of brushless linear or rotary motors.

It operates with digital motion controllers that use software to derive sinusoidal commutation waveforms from an encoder. Two differential amplifiers accept sinusoidal A and B input commands. The input commands have a 120 degrees phase difference. A high bandwidth current feedback loop is used to transform the input voltage commands to control motor phase A and B current. The amplifier derives phase C current.

Sinusoidal control of brushless DC motors minimizes torque or force ripple. Motor torque or force is approximately constant and independent of position. This is especially important when controlling linear motors in applications requiring micron-positioning accuracy.

The linear operating mode is highly advantageous for noise sensitive applications because it does not generate EMI. PWM switching noise is difficult to eliminate from sensitive sensors and transducers. This degrades velocity and position accuracy.

The controller employs two-stage current limiting. The first stage is a peak level with a time limit, then the second stage activates for a lower continuous current limit. A jumper selects the option of disabling the output when the continuous current limit is tripped. A trim potentiometer allows adjustment of the peak current up to the maximum value.

EUROCARD SERIES 52 AB LINEAR SINE DRIVE SERVO AMPLIFIER

GENERAL SPECIFICATIONS

MODEL	5-420-048-01	5-714-048-01
PEAK OUTPUT POWER	400 watts ¹	700 watts ¹
PEAK OUTPUT CURRENT	10 amps ¹ (1 sec typ.)	17 amps ¹ (1 sec typ.)
CONT. OUTPUT CURRENT	Note 1	Note 1
MAX AMPLIFIER DISSIPATION	98 watts ¹	140 watts ¹
OUTPUT VOLTAGE @ CONT. OUTPUT CURRENT	22V with 28V nominal bus	42V with 48V nominal bus
INPUT POWER BUS ⁴	24 to 56 VDC	24 to 56 VDC
INPUT ANALOG P.S.	±12 VDC	±12 VDC
POWER AMPLIFIER	Linear Mode Drive	
OPERATING TEMPERATURE	0 TO 50 Degrees C ¹	
CURRENT LOOP BANDWIDTH	Adjustable 0.5 to 4 KHZ typical	
LOGIC SUPPLY	5 VDC developed internally	
SIZE	100 W x 220 L x 44 H mm	
WEIGHT	.737 kg (26 oz)	

OPERATING CONTROL SIGNALS and INDICATORS

Input analog A & B control signal ²	± 10 Volts differential
Peak current limit	Adjustable
Drive Enable/Reset	5V logic
Direction Logic	5V logic
(+) Travel Limit	5V logic
(-) Travel Limit	5V logic
Brake ³	5V logic
Fault and/or Brake status	5V logic
Brake indicator	LED
Fault indicator	LED

AUXILIARY OUTPUTS

Motor current monitor: Analog Signal

FAULT PROTECTION CIRCUITS

Controller over temperature
Over current

EUROCARD SERIES 52 AB LINEAR SINE DRIVE SERVO AMPLIFIER

GENERAL SPECIFICATIONS

Notes:

1. Depends on ambient operating temperature, motor winding resistance, and heat sink airflow. For the rated maximum controller power dissipation, forced convection cooling with a minimum airflow of 100 CFM is required. Derate at 3 watts/degree C for ambient greater than 30 degrees C. Maximum controller dissipation occurs when the power out is minimum (motor stalled). It can be calculated as follows:

$$\begin{aligned}P_d &= P_{in} - P_{mtr} \\P_{in} &= (V_s)(I_o) \\P_{mtr} &= 1.5(I_o)^2(R_t/2)\end{aligned}$$

Where

P_d is controller dissipation in watts

P_{in} is input power

P_{mtr} is motor dissipation in watts

V_s is supply voltage

I_o is output current in amps

R_t is motor terminal-to-terminal resistance for wye winding in ohms.

Consult factory for assistance.

The controller employs two stage current limiting. The first stage is a peak level with a time limit, then the second stage activates for a lower continuous current limit.

2. Optional A and B $\pm 1\%$ gain match can be provided for precision applications.

3. Actuating brake at high motor speeds may damage the controller or motor. Consult factory for details.

4. The user should protect the Amplifier and any external circuits from a catastrophic failure by fusing the input power connections to the amplifier. See Application Note Supplementary Fuse Protection.

EUROCARD SERIES 52 AB LINEAR SINE DRIVE SERVO AMPLIFIER

EXTERNAL SIGNALS AND INTERCONNECTIONS

EDGE CONNECTOR J1 IS A 48 POLE DIN 41612 SERIES F
(REF EPT P/N 109-40064) or (FCI P/N 5159009486394111)

TERMINAL	SIGNAL NAME	DESCRIPTION
J1-2D, B, Z	MTR PHASE A	OUTPUT TO MOTOR PHASE A WINDING
J1-4D, B, Z	VDC POWER BUS RETURN	POWER SUPPLY RETURN
J1-6D, B, Z	MTR PHASE B	OUTPUT TO MOTOR PHASE B WINDING
J1-8D, B, Z	VDC POWER BUS IN	POWER SUPPLY INPUT <9>
J1-10D, B, Z	MTR PHASE C	OUTPUT TO MOTOR PHASE C WINDING
J1-12D	NC	NO CONNECTION
J1-12B	NC	NO CONNECTION
J1-12Z	MTR SHIELD	MOTOR SHIELD GND
J1-14D	(+) LIMIT	LOGIC 1= (+) LIMIT, <1>, <3>
J1-14B	MTR CUR	MOTOR CURRENT MONITOR, SF=SEE FUNC DIAG
J1-14Z	NC	NO CONNECTION
J1-16D	BRAKE CMD	LOGIC 1= BRAKE, <1>, <5>, <8>
J1-16B	ENABLE/RESET	LOGIC 0=ENABLE, <1>, <2>
J1-16Z	Vcc OUT	5VDC OUT
J1-18D	(-) LIMIT	LOGIC 1= (-) LIMIT, <1>, <4>
J1-18B	B COMMAND (+)	DIFFERENTIAL ANALOG \pm 10V B INPUT COMMAND, <6>
J1-18Z	B COMMAND (-)	DIFFERENTIAL ANALOG \pm 10V B INPUT COMMAND, <6>
J1-20D	+12VDC IN	12 V POWER SUPPLY INPUT
J1-20B	CURRENT FAULT OUT	LOGIC 1= CUR FAULT, <7>
J1-20Z	FAULT &/OR BRAKE OUT	LOGIC 1= FAULT AND, OR BRAKE ON <7>
J1-22D	DIR LOGIC	INPUT FROM MOTION CONTROLLER, LOGIC 1=(+) DIRECTION ¹
J1-22B	(-) 12VDC IN	(-) 12 V POWER SUPPLY INPUT
J1-22Z	NC	NO CONNECTION
J1-24D	NC	NO CONNECTION
J1-24B	NC	NO CONNECTION
J1-24Z	NC	NO CONNECTION
J1-26D	A COMMAND (+)	DIFFERENTIAL ANALOG \pm 10V A INPUT COMMAND, <6>
J1-26B	A COMMAND (-)	DIFFERENTIAL ANALOG \pm 10V A INPUT COMMAND, <6>
J1-26Z	NC	NO CONNECTION
J1-28D	\pm 12V RTN	\pm 12V POWER SUPPLY RETURN
J1-28B	NC	NO CONNECTION
J1-28Z	NC	NO CONNECTION
J1-30D, B	Vcc RTN OUT	5VDC RTN OUT
J1-30Z	NC	NO CONNECTION
J1-32D	CONT CUR FAULT	CONTINUOUS CURRENT FAULT, LOGIC 1=CC FAULT <7>
J1-32B	TEMPERATURE FAULT	LOGIC 1=TEMPERATURE FAULT <7>
J1-32Z	NC	NO CONNECTION

NOTES:

- <1> INTERNAL 10K PULL-UP RESISTOR TO 5VDC.
- <2> SWITCH S1 ON PCB IS IN SERIES WITH THIS LOGIC INPUT CMD. INSTALLATION OF JUMPER JP6 WILL DISABLE THE EXTERNAL CMD.
- <3> (+) LIMIT IS THE TRAVEL LIMIT THE MOTOR WILL DRIVE TOWARD WHEN THE DIRECTION SIGNAL IS A LOGIC 1. INSTALLATION OF JUMPER JP1 WILL DISABLE THIS FEATURE.
- <4> (-) LIMIT IS THE TRAVEL LIMIT THE MOTOR WILL DRIVE TOWARD WHEN THE DIRECTION SIGNAL IS A LOGIC 0. INSTALLATION OF JUMPER JP2 WILL DISABLE THIS FEATURE.
- <5> WHEN ACTIVE, THE MOTOR WINDINGS ARE SHORTED TOGETHER. IF THE BRAKE FEATURE IS NOT REQUIRED, INSTALL JUMPER JP3. CAUTION: BRAKE CMD AT HIGH SPEED MAY DAMAGE MOTOR AND/OR CONTROLLER. CONSULT FACTORY FOR ASSISTANCE.
- <6> COMMAND POLARITY DETERMINES DIRECTION OF ROTATION, SIGNAL AND SIGNAL RETURN CAN BE EXCHANGED. SEE <3>, <4>.
- <7> OUTPUT FROM CMOS PLD.
- <8> WE RECOMMEND THAT THE BRAKE CMD BE APPLIED FOR "POWER UP" AND THEN REMOVED FOR NORMAL OPERATION.
- <9> SEE APPLICATION NOTE SUPPLEMENTARY FUSE PROTECTION.

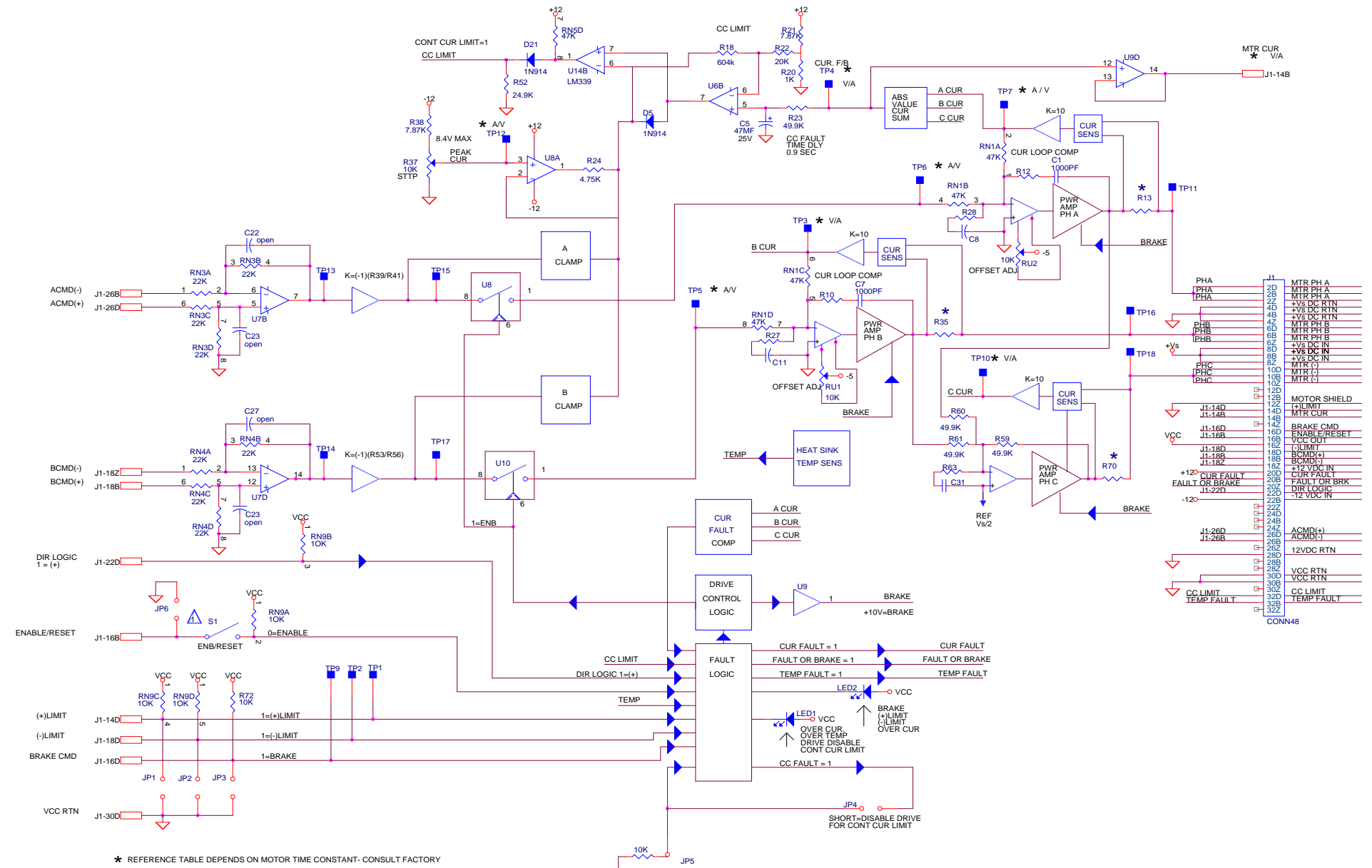

* REFERENCE TABLE DEPENDS ON MOTOR TIME CONSTANT- CONSULT FACTORY

Model	TP5, 6, 12	TP3, 4, 7, 10, J1-14B	CC LIMIT	R10,12,	R13, 35, 70
5-420-048-01	1 A/V	1 A/V	3V	1M	0.1R,1%,5W
5-714-048-01	2 A/V	2 A/V	1.5V	1M	.05R,1%,5W
6-420-048-01	1 A/V	1 A/V	3V	1M	0.1R,1%,5W
6-714-048-01	2 A/V	2 A/V	1.5V	1M	.05R,1%,5W

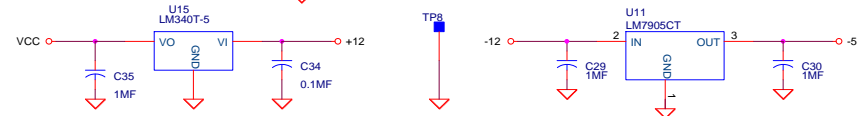

ELTROL CORPORATION CARLSBAD, CA		
Title FUNCTIONAL DIAGRAM 52 SERIES AMPLIFIER		
Size C	Document Number 3900052 AB.FNC	Rev 1
Date: Wednesday, January 16, 2008 Sheet 1 of 1		

NOTES: ENB WHEN SW1 BAT IS TOWARDS BOARD CENTER

EUROCARD SERIES 52 AB LINEAR SINE DRIVE SERVO AMPLIFIER

MOUNTING DIMENSIONS

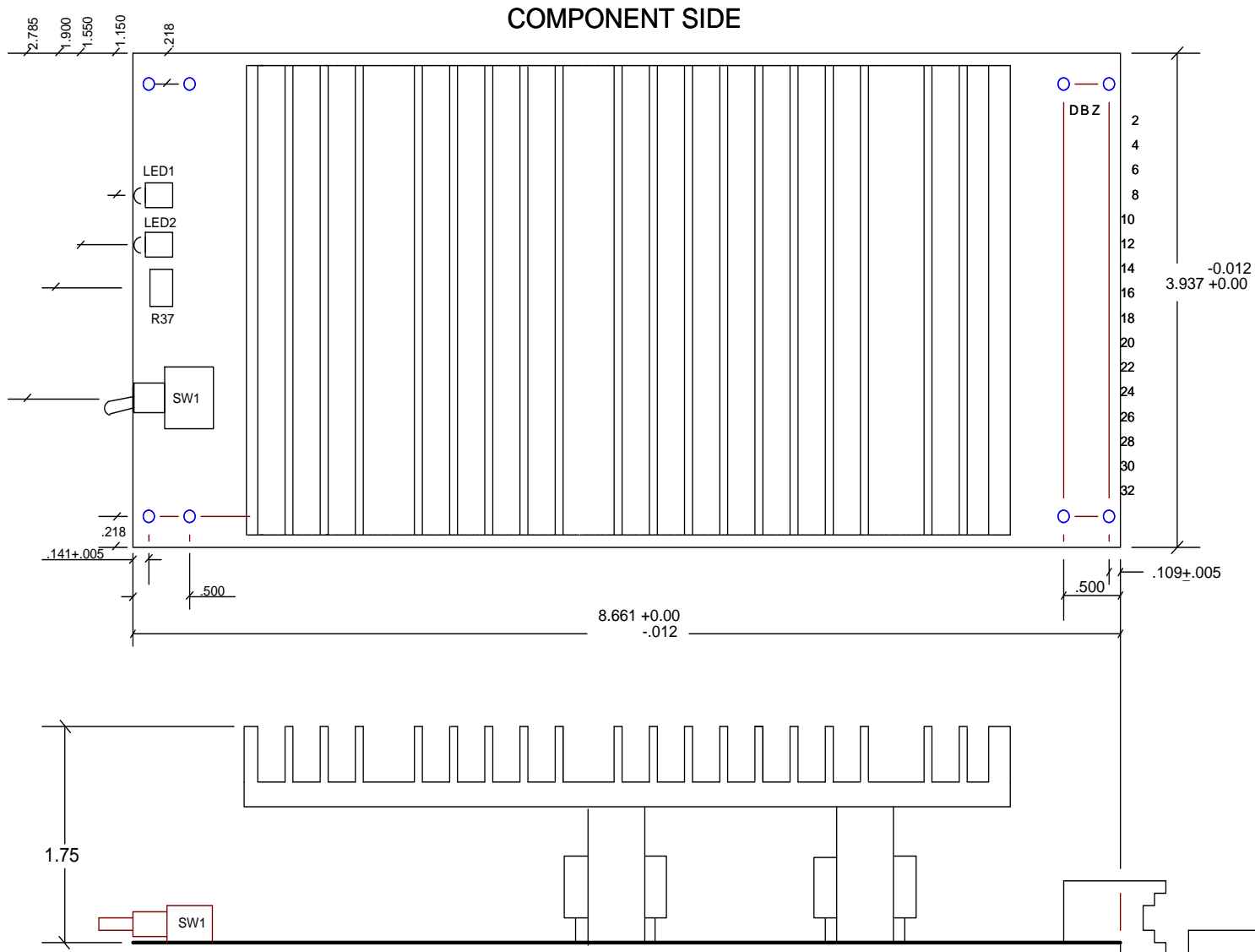

NOTES: 1. DO NOT SCALE
 2. ALL TOLERANCES ARE ±.002 UNLESS OTHERWISE SPECIFIED
 3. ALL DIMENSIONS SPECIFIED IN INCHES

ELTROL CORPORATION CARLSBAD, CA		
Title	SERIES 52 DATA SHEET OUTLINE	
Size	Document Number	Rev
B	3900052 OUTLINE.SCH	
Date: Tuesday, August 14, 2001 Sheet 1 of 1		